

Televes®

TOWERS



180 TOWERS

180 SE Towers

Series 180 SE is the most basic tower for heights up to 7.5 m with a 3 m mast on top.



QR-A00031

REF	DESCRIPTION	Surface treatment	Height (m)		Wt (Kg)
Sections					
3014	Upper section	Zn+RPR	1,25		4
3015	Upper section with ring	Zn+RPR	2,5		9,5
3017	Middle section	Zn+RPR	2,5		8,9
Accessories					
3019	Frame base for embedding	Zn+RPR	-		2,73
3020	Rigid base	Zn+RPR	-		1,17

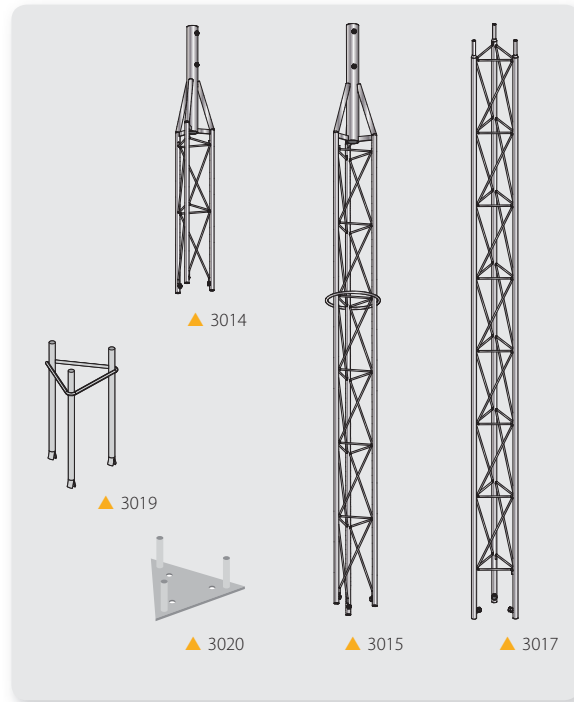

180 Towers

For joining sections they feature couplings to be threaded. Made of galvanized steel and bi-chromate coating, are supplied in two types of finishing: RPR or polyester painting. This model allows heights up to **26,5 m**, depending on the environmental conditions.



QR-A00032

- ▶ New record
- ▶ New design
- ▶ Automated manufacturing

REF	DESCRIPTION	Surface treatment	Height (m)		Wt (Kg)
Sections					
3021	Upper section	Zn+RPR	1		2,5
3032	Upper section	Zn+RPR	3		11
3031	Middle section	Zn+RPR	3		11
3037	Lower section (pivoting)	Zn+RPR	3		12,5
Accessories					
3048	Base for embedding (pivoting)	Zn+RPR	-		3,5
3038	Base plate for bolting	Zn+RPR	-		2,4
3029	Fixed frame for embedding	Zn+RPR	-		1,5
3058	Guy wire anchoring ring (180&360 series)	Zn+RPR	-		0,6
3034	Guy wire Ø 4 mm (100 m)	-	-		7,7

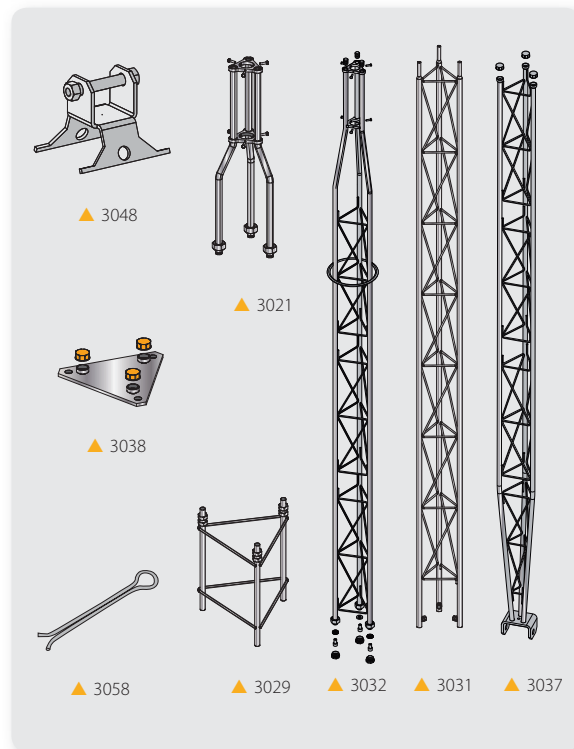

Zn+RPR: Zinc coating + Reactive Protecting Process.

Zn+P: Zinc coating + Painting with electrostatic spray (red or white) powder cured in oven.

HDG: Hot-dip galvanized.

180 TOWERS

Reference	3048
Description	Pivoting base (embedding), tower 180
Material	(1) Steel F626 (S 235), 8 mm thickness plate Re min. 235 N/m ² - Rn min. 340 N/m ² (2) Hardened and tempered steel
Weight	2,7 Kg

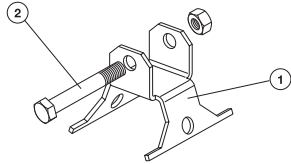

Reference	3031
Description	Middle section, tower 180
Material	(1) Steel ST 37-2, Ø 20 x 2 mm thickness Re min. 235 N/m ² - Rn min. 360/510 N/m ² (2) Steel S 275 JR Ø 6 mm Re min. 275 N/m ² - Rn min. 410/560 N/m ²
Weight	11,2 Kg
Surface facing the wind	0,236 m ² x 1,2 coef. = 0,283 m ²

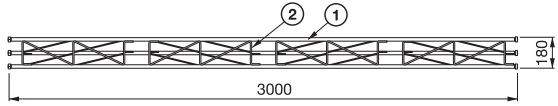

Reference	3037
Description	Lower section, tower 180
Material	(1) Steel ST 37-2, Ø 20 x 2 mm thickness Re min. 235 N/m ² - Rn min. 360/510 N/m ² (2) Steel S 275 JR, Ø 6 mm Re min. 275 N/m ² - Rn min. 410/560 N/m ² (3) Steel F626 (S 235), 10 mm thickness plate. Re min. 235 N/m ² - Rn min. 340 N/m ²
Weight	12,8 Kg
Surface facing the wind	0,27 m ² x 1,2 coef. = 0,273 m ²

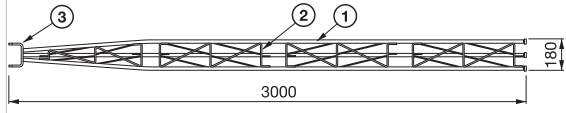

Reference	3032
Description	Upper section, tower 180
Material	(1) Steel ST 37-2, Ø 20 x 2 mm thickness. Re min. 235 N/m ² - Rn min. 360/510 N/m ² (2) Steel S 275 JR, Ø 6 mm Re min. 275 N/m ² - Rn min. 410/560 N/m ²
Weight	11,4 Kg
Surface facing the wind	0,227 m ² x 1,2 coef. = 0,272 m ²

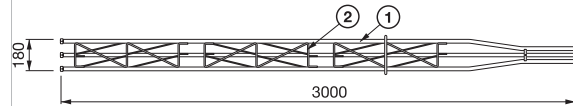

Reference	3038
Description	Base plate for bolting
Material	Steel F626 (S 235), 8 mm thickness plate
Weight	2,4 Kg

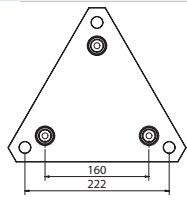

Reference	3058
Description	Guy wire anchoring ring
Material	Steel F621 - Ø 10 mm
Weight	0,6 Kg

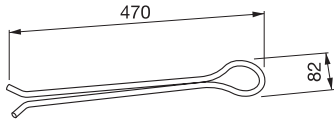

Structural cube for tower 180



QR-A00199

Allows creating versatile polyvalent metal structures to be assembled with sections of Televes towers 180 Series.

- ▶ Surface treatment: Galvanizing + bi-chromating + Reactive Sealing Treatment RPR.
- ▶ Construction of general purpose supports.
- ▶ Cables and/or pipes guiding.
- ▶ Tents and permanent or ephemeral constructions

REF	DESCRIPTION	Surface treatment	
305001	Structural cube 180 (200x200x200 mm)	Zn+RPR	

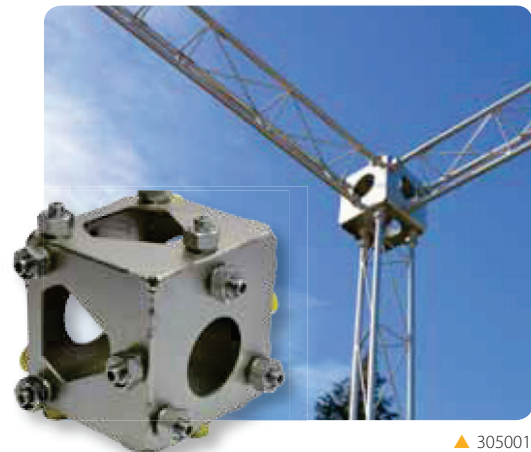

▲ 305001

Q1500 TOWERS

Q1500 STAINLESS STEEL Tower



QR-A00033

It allows to reach 14.5 m height with a completely new design made of high purity stainless steel.

INOX316 alloy removes the impurities of iron, preventing oxidation and providing greater long term safety with less maintenance.

The whole design of the tower, both the structure and the anchors of the winds have been based in Naval technology. This new configuration allows to install a tower 14.5 m height into a space of just 1.5 m radius, saving 401 m² of terrain compared to a conventional tower.

- ▶ Manufactured of **naval stainless steel INOX316**.
- ▶ Virtually **unlimited duration**.
- ▶ **High** mechanical strength and torsional rigidity.
- ▶ **Greater** ease of handling and assembly.
- ▶ **New system** of fittings that facilitate joining between sections.

The reference contains all accessories for installation:

- ▶ 3 middle sections of 3 m
- ▶ 1 upper section of 3 m
- ▶ 1 mast of 3 m.
- ▶ 1 guy wire anchoring cross head.
- ▶ 1 tower base.
- ▶ 3 guy wire bases.
- ▶ 3 cables 4 mm Ø
- ▶ 6 cables 5 mm Ø
- ▶ Turnbuckles, screws, clamps and accessories.

REF	DESCRIPTION	Height (m)		Wt (Kg)
3049	Kit Tower Q1500 made of stainless steel, supplied with all elements to erect the tower.	14,5		93



Base section + guy wire anchoring

Middle cross section

Dimensioning of guy wires

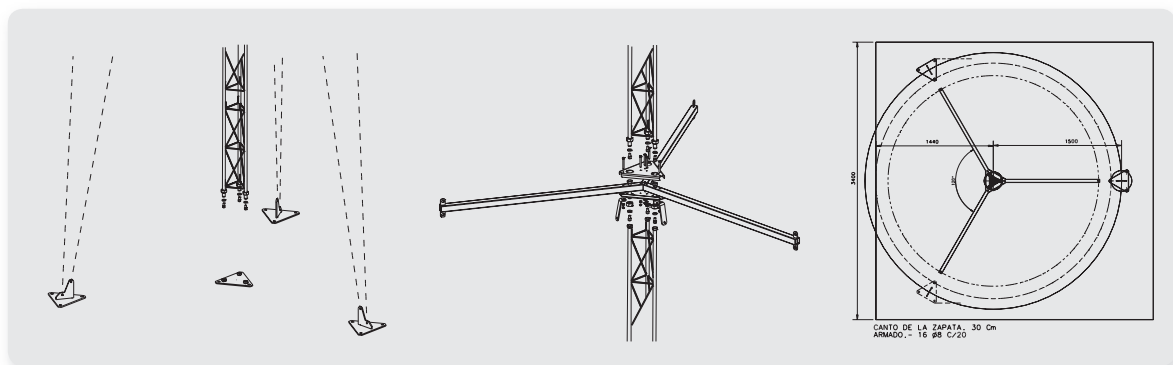

APPLIED STANDARDS (WIND SECTOR)

In European legislation does not exist, as in USA, a specific standard for this type of structure, so we will have to refer to Eurocodes:

- ▶ **EN 1990** (Basis of Structural Design).
- ▶ **EN 1991** (Actions on Structures).
- ▶ **EN 1993** (Design of Steel Structures).

Having analyzed the TIA 222-G standards and Eurocodes, say that they are similar. This is something to be expected since the committees developing these standards, base their work on all that is already standardized as well as on the experience of other organizations and countries.

Thereby, it is achieved a deeper understanding and knowledge, both of these structures and the conditions to which they may be subject.

Below is the table with the equivalence between both the American National Standard TIA 222-G ("Structural Standards for Antenna Supporting Structures and Antennas"), and the above mentioned European EN Eurocodes EN 1990, EN 1991 and EN 1993.

Wind speed

▶ **TIA 222-G. Basic wind speed (V_b):**

"3-second gust wind speed at 33 ft (10 m) above the ground in exposure category C, this is, open terrain with scattered obstructions having heights generally less than 30 ft (9.1 m) - including flat, open country, grasslands and shorelines in hurricane prone regions - for a 50-year mean recurrence interval".

▶ **EN-1991-14. Basic wind velocity ($V_{b,0}$):**

It is the basic wind velocity, defined as a function of wind direction and time of year at 10 m above the ground of terrain of category II, this is, an area with low vegetation such as grass and isolated obstacles (trees, buildings) with separations of at least 20 obstacle heights, for a 50-year mean recurrence interval.

- ▶ **The difference** between these standards is that, in the American standard "TIA 222-G" is considered a 3-second gust, while in the European Eurocodes are considered 10-min average.

Wind speed equivalences	
TIA 222-G 3-sec gust (Km/h)	Eurocodes Average speed 10-min (Km/h) ⁽¹⁾
97	68
113	79
129	90
145	100
161	111
177	122
193	134
209	145
225	156
241	172
257	179
274	190

(1): [Km/h] = [m/s]*[0.278]

Speed	American Standard TIA 222-G	European Standard Eurocodes EN-1991-14
Wind 1	180 Km/h (Vb)	126 Km/h (35 m/s) (Vr)
Wind 2	160 Km/h (Vb)	112 Km/h (31,2 m/s) (Vr)

* Other speeds can be calculated by interpolation.

In Spain, the wind of reference (Vr) indicative by Eurocodes is between 24 and 28 m/s, which is why Televes towers are calculated with values higher than those required. View map.

Terrain Category

Define different geographical areas depending on what they are exposed to the wind.

TIA 222-G

- B** "Urban and suburban areas, wooded areas, or other terrain with numerous closely spaced obstructions having the size of single-family dwellings or larger. Use of this exposure shall be limited to those areas for which terrain representative of Exposure B surrounds the structure in all directions for a distance of at least 2,630 ft (800 m) or ten times the height of the structure, whichever is greater".
- C** "Open terrain with scattered obstructions having heights generally less than 30 ft (9.1 m). This category includes flat, open country, grasslands and shorelines in hurricane prone regions".
- D** "Flat, unobstructed shorelines exposed to wind flowing over open water (excluding shorelines in hurricane prone regions) for a distance of at least 1 mile (1.61 Km). Shorelines in Exposure D include inland waterways, lakes and non-hurricane coastal areas. Exposure D extends inland a distance of 660 ft (200 m) or ten times the height of the structure, whichever is greater. Smooth mud flats, salt flats and other similar terrain shall be considered as Exposure D".

EN-1991-14

- O** Sea or coastal area exposed to the open sea.
- I** Lakes or flat and horizontal area with negligible vegetation and without obstacles.
- II** Area with low vegetation such as grass and isolated obstacles (trees, buildings) with separations of at least 20 obstacle heights.
- III** Area with regular cover of vegetation or buildings or with isolated obstacles with separations of maximum 20 obstacle heights (such as villages, suburban terrain, permanent forest).
- IV** Area in which at least 15 % of the surface is covered with buildings and their average height exceeds 15 m.

Equivalences between terrain categories	
TIA 222-G	Eurocode EN-1991-14
B	III-IV
C	II
D	O-I

APPLIED STANDARDS (WIND SECTOR)

Topographic Category (TIA 222-G & EN-1991-14)

- 1 "No abrupt changes in general topography, e.g. flat or rolling terrain, no wind speed-up consideration shall be required."
- 2 "Structures located at or near the crest of an escarpment. Wind speed-up shall be considered to occur in all directions. Structures located vertically on the lower half of an escarpment or horizontally beyond 8 times the height of the escarpment from its crest, shall be permitted to be considered as Topographic Category 1".
- 3 "Structures located in the upper half of a hill. Wind speed-up shall be considered to occur in all directions. Structures located vertically on the lower half of a hill shall be permitted to be considered as Topographic Category 1".
- 4 "Structures located in the upper half of a ridge. Wind speed-up shall be considered to occur in all directions. Structures located vertically on the lower half of a ridge shall be permitted to be considered as Topographic Category 1".

Classification of structures

Classification of structures allows for the adjustment of wind, ice and earthquake loading to match the reliability requirements for a specific application, based on the type of service provided and on the structure's potential hazard to human life and property.

TIA 222-G

- I "Structures that due to height, use or location represent a low hazard to human life and damage to property in the event of failure and/or used for services that are optional and/or where a delay in returning the services would be acceptable".
- II "Structures that due to height, use or location represent a substantial hazard to human life and/or damage to property in the event of failure and/or used for services that may be provided by other means".
- III "Structures that due to height, use or location represent a high hazard to human life and/or damage to property in the event of failure and/or used primarily for essential communications".

EN-1993-3-1

- 1 Towers and masts built on unmanned sites in open countryside; towers and masts, the failure of which would not be likely to cause injury to people.
- 2 All towers and masts that cannot be defined as class 1 or 3.
- 3 Towers and masts erected in urban locations, or where failure is likely to cause injury or loss of life; towers and masts used for vital telecommunication facilities; other major structures where the consequences of failure would be likely to be very high.

Equivalences between classes of structures

TIA 222-G	Eurocodes EN-1993-3-1
I	1
II	2
III	3

Safety factors

Televés is in a position to claim that their towers meet all safety factors set in both American TIA 222 G standard and the Eurocodes.

Guy wire stressing

Following recommendations of the Eurocodes, we perform all our calculations taking into account a pre-stressing of the guy wires than 10% of the breaking strength of the cable. This pre-tension prevents the possibility of occurrence of a negative effect of resonance on the tower, due to the low frequency high amplitude vibrations (galloping) on the cable.

By decreasing this initial tension, it is obvious that decreases the load on the tower base, and then it can withstand more ice thickness. We do not recommend this practice, since the probability of exceeding 5 mm thickness of ice is very low, so it is not necessary tension below 10%.

Calculation Software

Televés conducts studies of all towers by means of the advanced American calculation software "RISA TOWERS". This program uses the standard TIA/222-G (USA standard), in force for more than 60 years, for their calculations and simulations.

This way, it is possible to do a simulation of all different conditions that are given throughout the European geography.

When doing a project of any tower, you should always keep in mind the following:

- ▶ Tower height and structure classification.
- ▶ Basic wind velocity in the zone.
- ▶ Topographic and terrain categories.
- ▶ Installation conditions.

After analyzing all this data, it is possible to obtain graphs of deflection, out-of-plumb, torque, pressure (with or without ice), thickness, stress diagrams, bending moment diagrams, graphs of stress of the tower from different faces, and compression capacity of the legs, the configuration of the towers and all its technical characteristics.

APPLIED STANDARDS (WIND SECTOR)

European Wind Speed Reference Map

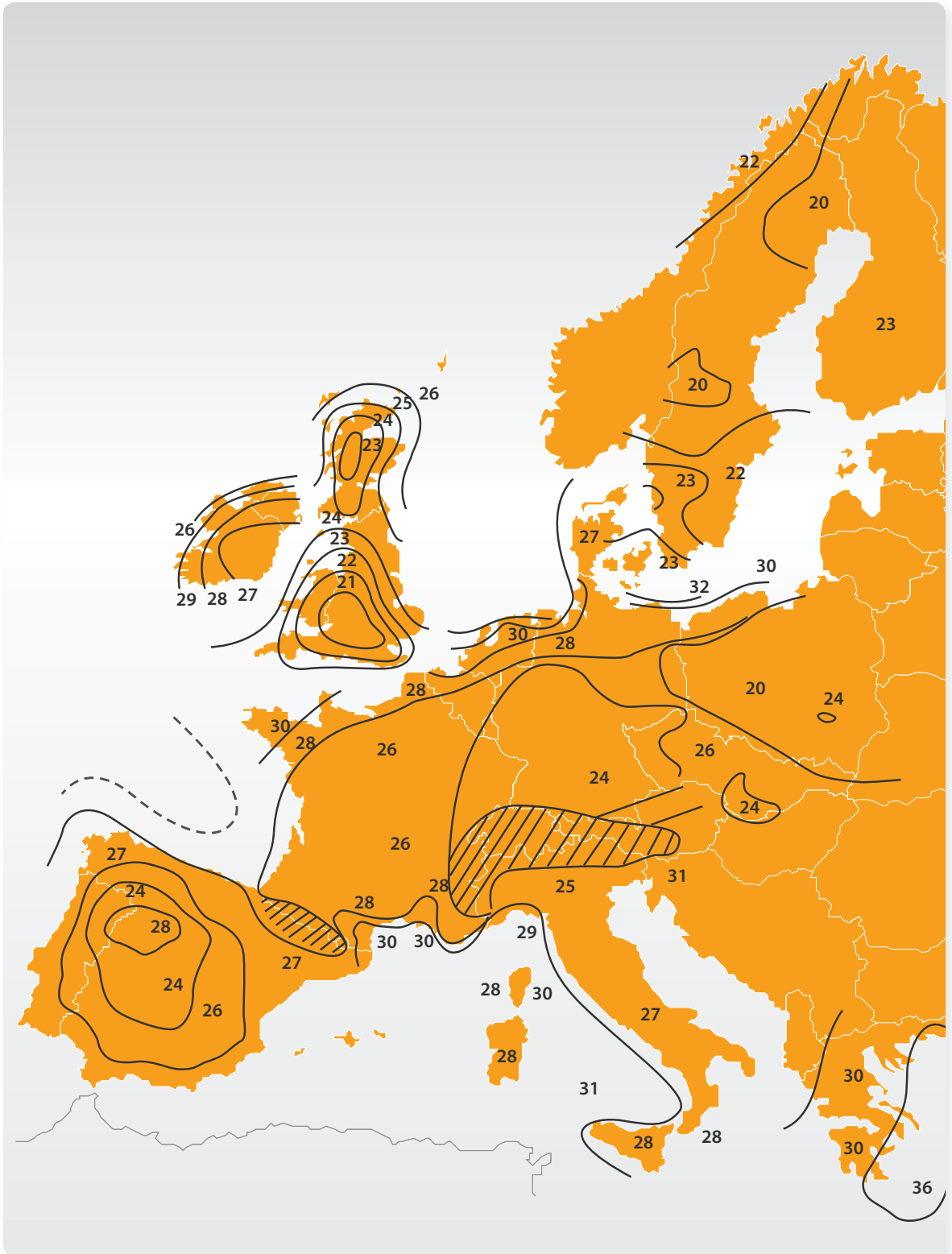

Source: Regulations UNE-ENV 1991-2-4 Eurocodes

360 TOWERS (WIND SECTOR)

360 Towers

Maximum height recommended for these towers is 47.5 m, depending on the wind conditions.



QR-A00034

REF	DESCRIPTION	Surface treatment	Height (m)		Wt (Kg)
Sections					
3085	Upper section	Zn+RPR	3	ⓐ	23,4
308501	Upper section	Zn+P	3	Ⓡe	23,4
308502	Upper section	Zn+P	3	ⓐ	23,4
3087	Middle section	Zn+RPR	3	ⓐ	24,3
308701	Middle section	Zn+P	3	Ⓡe	24,3
308702	Middle section	Zn+P	3	ⓐ	24,3
3086	Lower section (pivoting)	Zn+RPR	3	ⓐ	22,7
308601	Lower section (pivoting)	Zn+P	3	Ⓡe	22,7
308602	Lower section (pivoting)	Zn+P	3	ⓐ	22,7
Accessories					
3088	Pivoting base (embedding)	Zn+RPR	-	ⓐ	7
3089	Fixed frame for embedding	Zn+RPR	-	ⓐ	3,2
3058	Guy wire anchoring ring	Zn+RPR	-	ⓐ	0,6
3059	Lashing steel wire Ø 5 mm (100 m)	-	-	ⓐ	115

Zn+RPR: Zinc coating + Reactive Protecting Process.

Zn+P: Zinc coating + Painting with electrostatic spray (red or white) powder cured in oven.

HDG: Hot-dip galvanized.

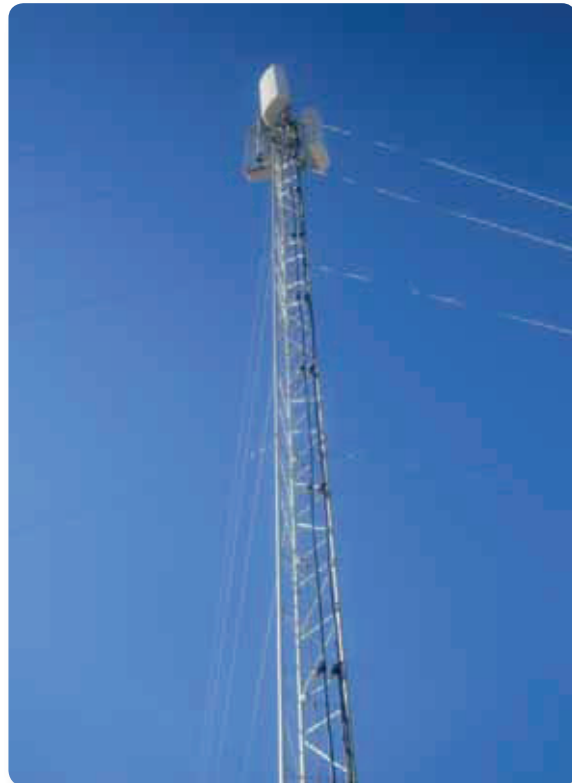

▲ Tower Series 360

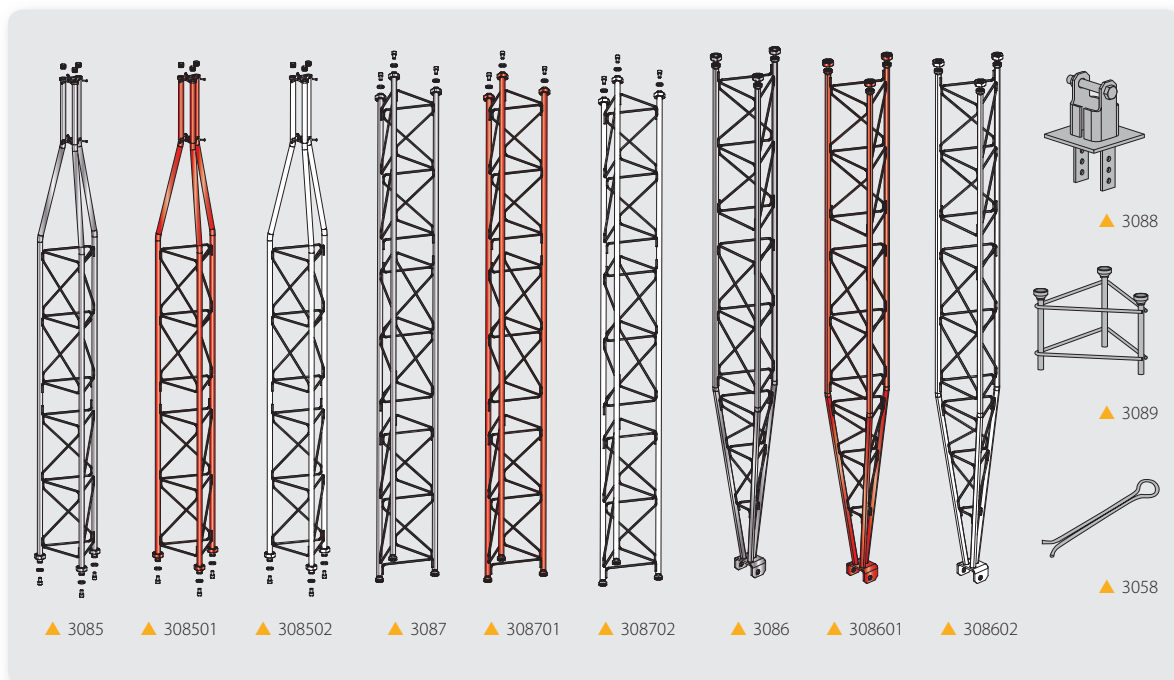

360 TOWERS (WIND SECTOR)

Reference	3088
Description	Pivoting base (embedding)
Material	(1) Steel F626 (S 235), 12 mm thickness plate Re min. 235 N/mm ² - Rn min. 340 N/mm ²
Finishing	Galvanized + bi-chromated + RPR
Weight	7 Kg

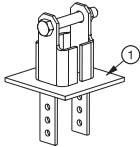

Reference	3089
Description	Fixed frame for embedding
Material	(1) Steel F626, Ø 18 mm. Re min. 235 N/mm ² - Rn. 340 N/mm ² (2) Steel F626, Ø 10 mm. Re min. 235 N/mm ² - Rn. 340 N/mm ²
Finishing	Galvanized + bi-chromated + RPR
Weight	3,2 Kg

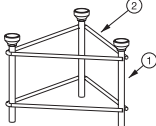

Reference	308601
Description	Lower section. RED color.
Material	(1) Steel ST 37-2, Ø 30 ext. x 2 mm thickness Re min. 235 N/mm ² - Rn min. 360/510 N/mm ² (2) Steel S 275 JR, Ø 09 mm thickness Re min. 275 N/mm ² - Rn min. 410/560 N/mm ² (3) Steel F626 (S 235), 10 mm thickness plate Re min. 235 N/mm ² - Rn. 340 N/mm ²
Finishing	Galvanized + bi-chromated + painted with 60-80 µm thickness of electrostatic spray red powder (RAL3020)
Weight	25 Kg
Surface facing the wind	0,355 m ² x 1,2 coef. = 0,426 m ²

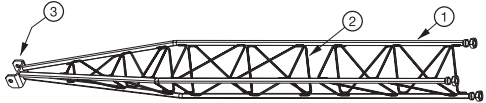

Reference	308701	308702
Description	Middle section. RED color	Middle section. WHITE color
Material	(1) Steel ST 37-2, Ø 30 ext. x 2 mm thickness Re min. 235 N/mm ² - Rn min. 360/510 N/mm ² (2) Steel S 275 JR, Ø 9 mm Re min. 275 N/mm ² - Rn min. 410/560 N/mm ²	
Finishing	Galvanized + bi-chromated + painted with electrostatic spray red powder (RAL3020)	
Weight	25 Kg	
Surface facing the wind	0,365 m ² x 1,2 coef. = 0,438 m ²	

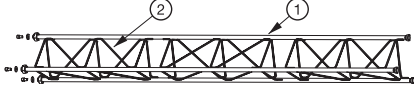

Reference	308501
Description	Upper section. RED color.
Material	(1) Steel ST 37-2, Ø 30 ext. x 2 mm thickness Re min. 235 N/mm ² - Rn min. 360/510 N/mm ² (2) Steel S 275 JR, Ø 9 mm thickness Re min. 275 N/mm ² - Rn min. 410/560 N/mm ² (3) Steel F626 (S 235), 10 mm thickness plate Re min. 275 N/mm ² - Rn. 410/560 N/mm ²
Finishing	Galvanized + bi-chromated + painted with 60-80 µm thickness of electrostatic spray red powder (RAL3020)
Weight	23 Kg
Surface facing the wind	0,333 m ² x 1,2 coef. = 0,40 m ²

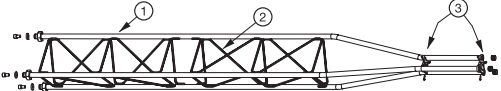

Reference	3058
Description	Guy wire anchoring ring
Material	Steel F-621 Ø 10 mm
Weight	0,6 Kg

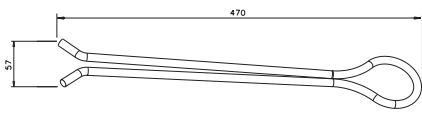

450 TOWERS (WIND SECTOR)

450 Towers

Two types of sections are available to be used in accordance with the wind speed conditions: reinforced sections (thicker lattice and wall tube) and slight sections.

This tower is recommended for heights from 46,5 m up to 81 m. Furthermore, can be reached 120 m height when its sections are used in conjunction with sections of towers Series 550.

The surface plate (Ref. 312901) allows to install a Pivot base without the need of concrete.



QR-A00035

REF	DESCRIPTION	Surface treatment	Height (m)		Wt (Kg)
Sections					
3133	Upper section	Zn+P	3		34,5
3131	Middle section	Zn+P	3		37,5
313101	Middle section	Zn+P	3		37,5
3132	Reinforced middle section	Zn+P	3		41
313201	Reinforced middle section	Zn+P	3		41
3130	Reinforced lower pivot section	Zn+P	3		43,5
Accessories					
3134	Pivoting base (embedding)	Zn+RPR	-		15,4
312901	Surface plate for pivoting base (Ref. 3134 and Ref. 3142)	Zn+RPR	-		67
3144	Guy wire anchoring ring	Zn+RPR	-		5

Zn+RPR: Zinc coating + Reactive Protecting Process.

Zn+P: Zinc coating + Painting with electrostatic spray (red or white) powder cured in oven.

HDG: Hot-dip galvanized.



▲ Tower Series 450

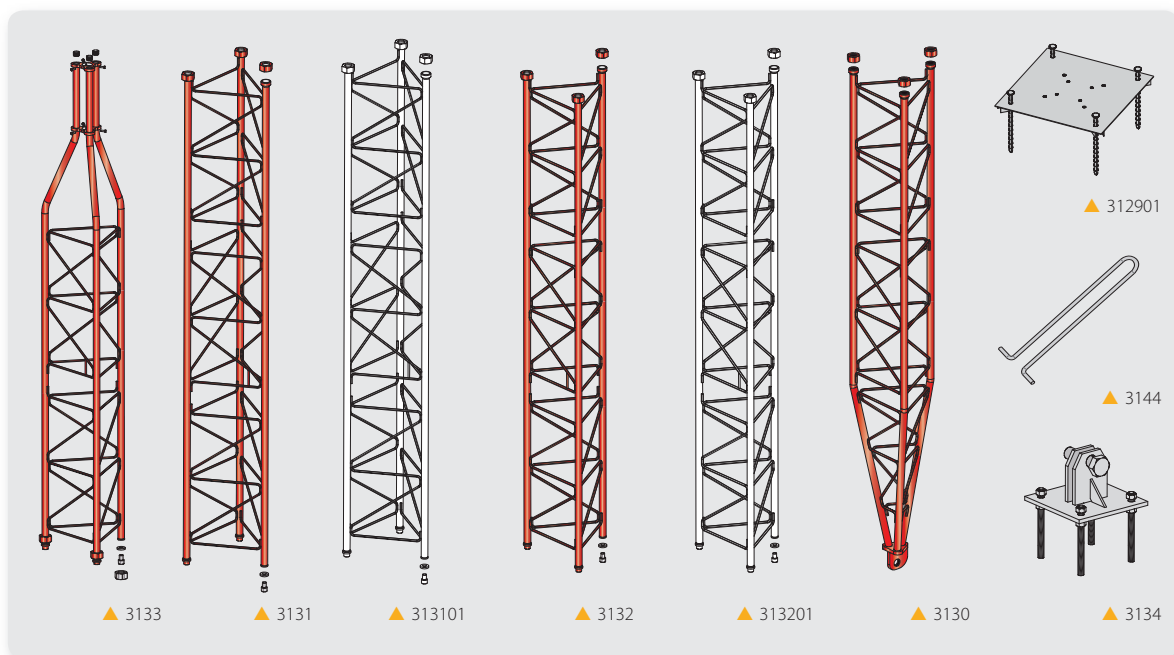

450 TOWERS (WIND SECTOR)

Reference	3134
Description	Pivoting base (embedding)
Material	(1) Steel F626 (S 235), 15 mm thickness plate Re min. 235 N/mm ² - Rn min. 340 N/mm ² (2) Hardened and tempered steel.
Weight	15,4 Kg

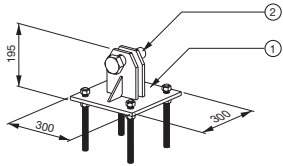

Reference	3130
Description	Reinforced lower section, tower 450. RED color.
Material	(1) Steel ST 37-2, Ø 40 ext. x 3 mm thickness Re min. 235 N/mm ² - Rn min. 360/510 N/mm ² (2) Steel S 275 JR, Ø 12 mm Re min. 275 N/mm ² - Rn min. 410/560 N/mm ² (3) Steel F626 (S 235), 12 mm thickness plate Re min. 235 N/mm ² - Rn. 340 N/mm ²
Finishing	Galvanized + bi-chromated + painted with 60-80 µm thickness of electrostatic spray powder (RED RAL3020)
Weight	43,5 Kg
Surface facing the wind	0,495 m ² x 1,2 coef. = 0,594 m ²

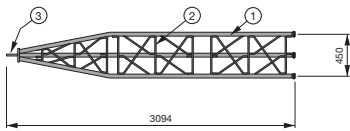

Reference	3132	313201
Description	Reinforced middle section, tower MR450. RED color.	Reinforced middle section MR450. WHITE color.
Material	(1) Steel ST 37-2, Ø 40 ext. x 3 mm thickness Re min. 235 N/mm ² - Rn min. 360/510 N/mm ² (2) Steel S 275 JR, Ø 12 mm Re min. 275 N/mm ² - Rn min. 410/560 N/mm ²	
Finishing	Galvanized + bi-chromated + painted with 60-80 µm thickness of electrostatic spray powder (RED RAL3020) (WHITE RAL9002)	
Weight	40,8 Kg	
Surface facing the wind	0,517 m ² x 1,2 coef. = 0,621 m ²	

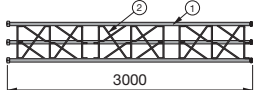

Reference	3131	313101
Description	Middle section, tower ML450. RED color.	Middle section, tower ML450. WHITE color.
Material	(1) Steel ST 37-2, Ø 38 ext. x 2,6 mm thickness Re min. 235 N/mm ² - Rn min. 360/510 N/mm ² (2) Steel S 275 JR, Ø 10 mm Re min. 275 N/mm ² - Rn min. 410/560 N/mm ²	
Finishing	Galvanized + bi-chromated + painted with 60-80 µm thickness of electrostatic spray powder (RED RAL3020) (WHITE RAL9002)	
Weight	37,5 Kg	
Surface facing the wind	0,473 m ² x 1,2 coef. = 0,568 m ²	

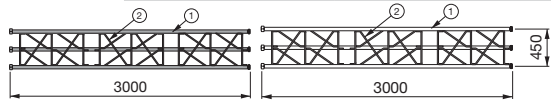

Reference	3133
Description	Upper section, tower ML450. RED color.
Material	(1) Steel ST 37-2, Ø 38 ext. x 2,6 mm thickness Re min. 235 N/mm ² - Rn min. 360/510 N/mm ² (2) Steel S 275 JR, Ø 10 mm Re min. 275 N/mm ² - Rn min. 410/560 N/mm ² (3) Steel F626 (S 235), 15 mm thickness plate Re min. 235 N/mm ² - Rn. 340 N/mm ²
Finishing	Galvanized + bi-chromated + painted with 60-80 µm thickness of electrostatic spray powder (RED RAL3020)
Weight	34,5 Kg
Surface facing the wind	0,432 m ² x 1,2 coef. = 0,518 m ²

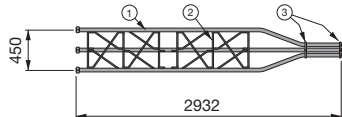

Reference	3141
Description	Transition section of tower 550 to 450. RED color.
Material	(1) Steel ST 37-2, Ø 60 ext. x 4 mm thickness Re min. 235 N/mm ² - Rn min. 360/510 N/mm ² (2) Steel S 275 JR, Ø 14 mm Re min. 275 N/mm ² - Rn min. 410/560 N/mm ²
Finishing	Galvanized + bi-chromated + painted with 60-80 µm thickness of electrostatic spray powder (RED RAL3020)
Weight	82 Kg
Surface facing the wind	0,707 m ² x 1,2 coef. = 0,848 m ²

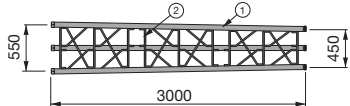

Reference	3144
Description	Guy wire anchoring ring
Material	Corrugated steel B400 SD UNE 36065 Ø 20 mm.
Weight	5 Kg

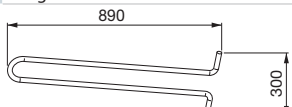

550 TOWERS (WIND SECTOR)

550 Towers

Designed as a reinforcement of the tower 450, this series is made up of sections (lower and middle) to reach elevated heights (up to 120 m) in extreme conditions (wind speeds up to 200 Km/h).

The surface plate (Ref. 312901) allows to install a Pivot base without the need of concrete.



QR-A00134

REF	DESCRIPTION	Surface treatment	Height (m)		Wt (Kg)
Series 550					
Sections					
3141	Transition section of tower 550 to 450	Zn+P	3	Re	82
3140	Middle section	Zn+P	3	Re	85
314001	Middle section	Zn+P	3	W	85
313901	Lower pivot section	Zn+P	3	Re	97
Accessories					
3142	Pivoting base	Zn+RPR	-	Re	72
312901	Surface plate for pivoting base (Ref. 3134 and Ref. 3142)	Zn+RPR	-	G	67
3143	Fixed base	Zn+RPR	-	G	55
3144	Guy wire anchoring ring	Zn+RPR	-	G	5

Zn+RPR: Zinc coating + Reactive Protecting Process.

Zn+P: Zinc coating + Painting with electrostatic spray (red or white) powder cured in oven.

HDG: Hot-dip galvanized.

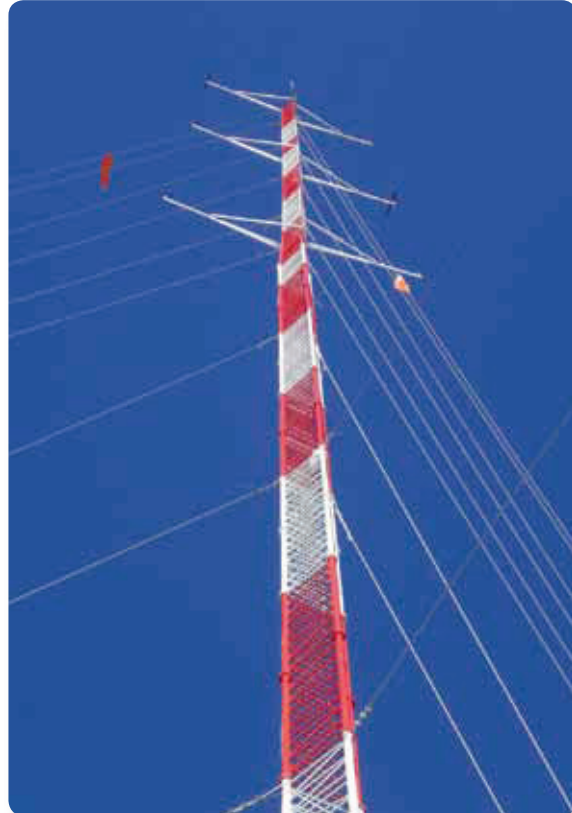

▲ Tower Series 550

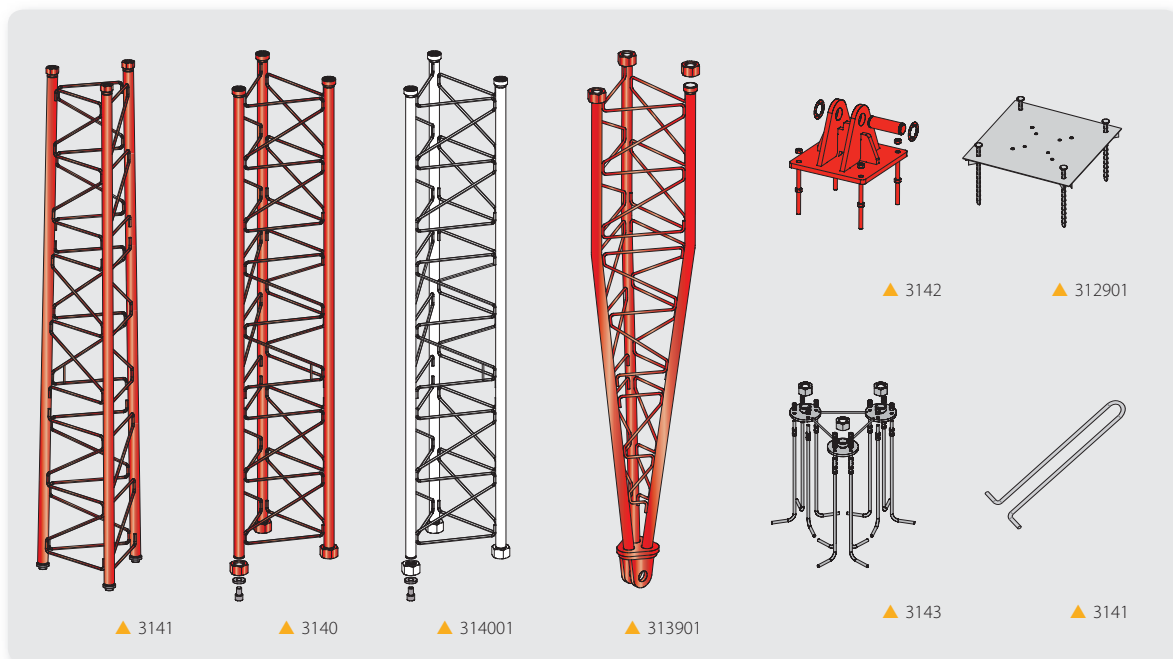

550 TOWERS (WIND SECTOR)

Reference	3142
Description	Pivoting base, tower 550
Material	(1) Steel F6210, 25 mm thickness plate Re min. 275 N/mm ² Rn min. 430/540 N/mm ² (2) Hardened and tempered steel.
Finishing	Galvanized + bi-chromated + RPR
Weight	72 Kg

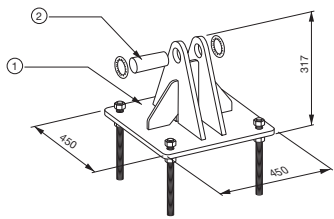

Reference	313901
Description	Lower section, tower 550. RED color.
Material	(1) Steel ST 37-2, Ø 60 ext. x 4 mm thickness Re min. 235 N/mm ² - Rn min. 360/510 N/mm ² (2) Steel S 275 JR, Ø 14 mm Re min. 275 N/mm ² - Rn min. 410/560 N/mm ²
Finishing	Galvanized + bi-chromated + painted with 60-80 µm electrostatic spray powder (RED RAL3020)
Weight	97 Kg
Surface facing the wind	0,704 m ² x 1,2 coef. = 0,845 m ²

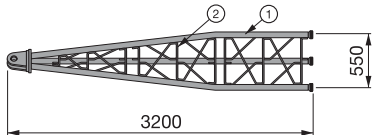

Reference	3140	314001
Description	Middle section, tower 550. RED color.	Middle section, tower 550. WHITE color.
Material	(1) Steel ST 37-2, Ø 60 ext. x 4 mm thickness Re min. 235 N/mm ² - Rn min. 360/510 N/mm ² (2) Steel S 275 JR, Ø 14 mm Re min. 275 N/mm ² - Rn min. 410/560 N/mm ²	
Finishing	Galvanized + bi-chromated + painted with 60-80 µm electrostatic spray powder (RED RAL3020) (WHITE RAL9002)	
Weight	85 Kg	
Surface facing the wind	0,718 m ² x 1,2 coef. = 0,862 m ²	

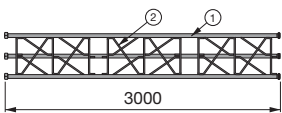

Reference	3141
Description	Transition section from tower 550 to 450. RED color.
Material	(1) Steel ST 37-2, Ø 60 ext. x 4 mm thickness Re min. 235 N/mm ² - Rn min. 360/510 N/mm ² (2) Steel S 275 JR, Ø 14 mm Re min. 275 N/mm ² - Rn min. 410/560 N/mm ²
Finishing	Galvanized + bi-chromated + painted with 60-80 µm electrostatic spray powder (RED RAL3020)
Weight	82 Kg
Surface facing the wind	0,707 m ² x 1,2 coef. = 0,848 m ²

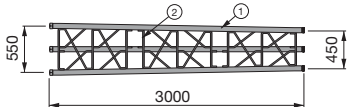

Reference	3144
Description	Guy wire anchoring ring
Material	Corrugated steel B400 SD UNE 36065 Ø 20 mm.
Weight	5 Kg

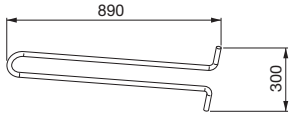

The heights given are just for guidance, and depend on the load and conditions to which the tower is subject. We make estimates and compositions of sections for a requested tower height: asistenciatecnica@televes.com

MOUNTING RECOMMENDATIONS

- ▶ To ensure that the threads of the couplings do not deteriorate during the handling process, the sections are supplied with nuts installed on their threads that are exposed to possible damage.
- ▶ Once on site, and before mounting the tower, proceed to take out the nuts and put them on their corresponding thread on the opposite end of the section (see fig. 2).

Installation of nuts for shipping

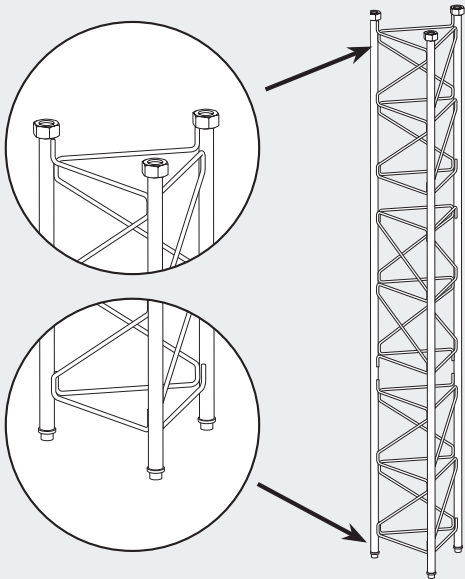

Section ready to be mounted

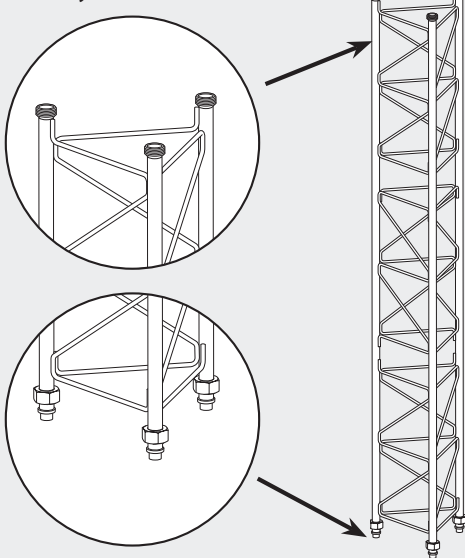
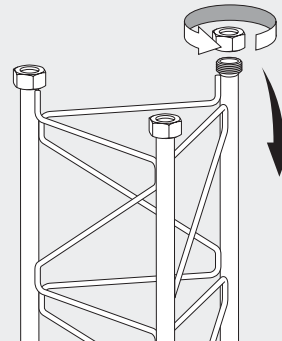

Fig. 2

Remove the nuts from the top of the section.

1



Remove the allen screws and washers from the other end of the section.

2

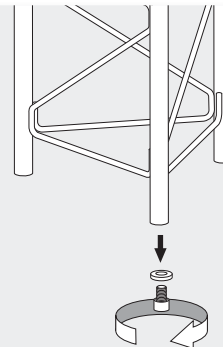

Once free of screw and washer, insert the nut into the tube and reinstall the washer and Allen screw, as shown.

Max. Torque: 400 Nm.

3

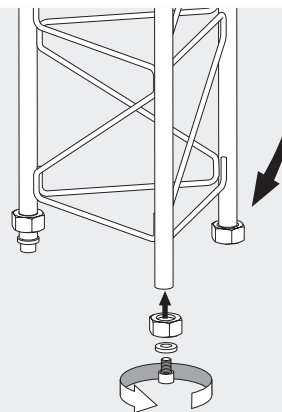

MOUNTING RECOMMENDATIONS

Structure (sections/guy wires)

The guy wire clamps must be retightened later after the first wire pull.

The body of the guy wire clamp must be mounted over the live end of the cable and all of them in the same position, as shown in the figure.

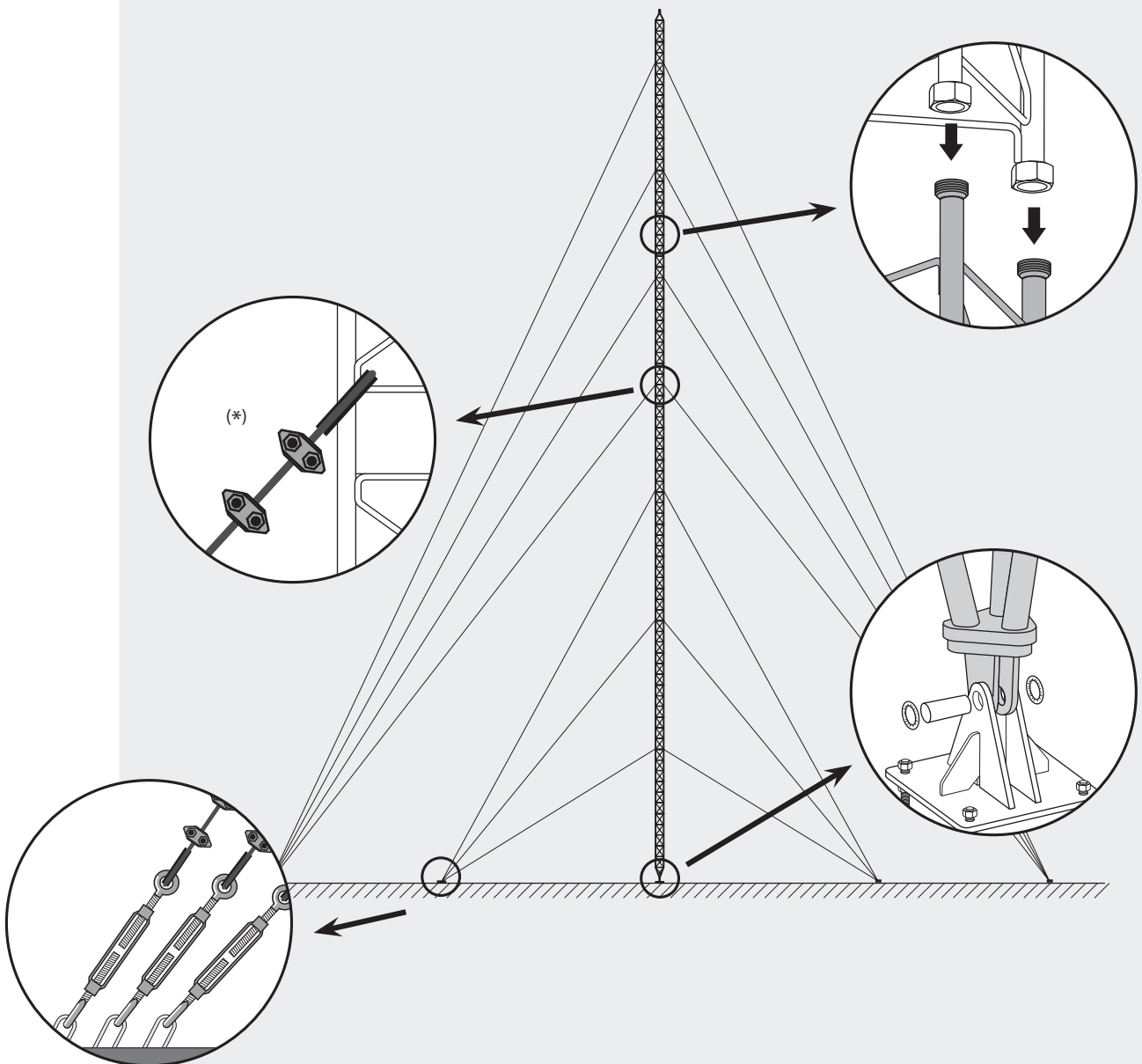
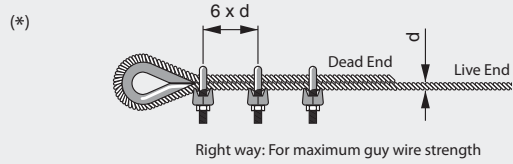

WARNING

Tower installations should only be calculated and constructed by specialised professionals as these fall under their responsibility. Mounting instructions provided in this document are intended for information only, and the data given does not, in any way, affect the responsibility of the manufacturer who only guarantees his own products, provided that they are used under normal conditions.

It will be necessary to conduct a project to install the tower for each specific site, which should take into account both the individual stresses and the recalculation of foundations in accordance with the relevant geotechnical study.

The towers will be assembled by competent personnel and skilled in climbing, using all means of protection required to safeguard the security in vertical works.